

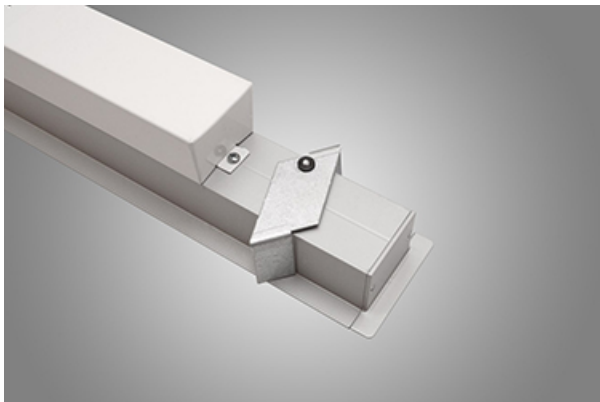

X-LINE SLIM RECESSED LED

Recessed luminaires

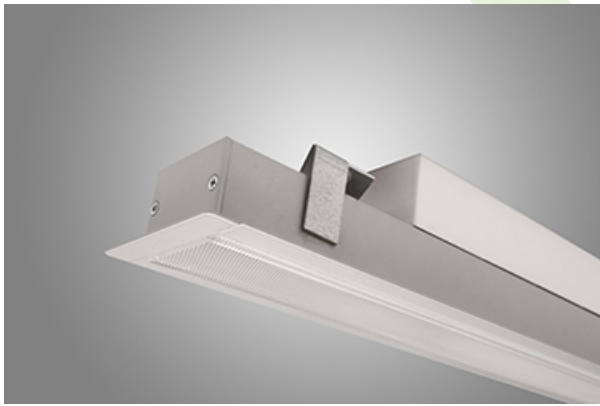

Luminaire made of aluminium profile. Compared to traditional X-Line G/K LED, the size has been reduced and the structure enclosed in a narrower profile, which allows a more elegant aspect of the product. X-Line Slim Recessed uses an opaline Micro PRM diffuser. All this makes it possible to adjust light and create lighting systems, easing the creation of a comfortable view of indoor spaces and their aesthetics. X-Line Slim Recessed is designed for built-in installation on ceilings.



Main parameters:

Name	Luminous flux LED [lm]	Power of luminaire [W]	Color [K]	Dimensions A x B x H [mm]
X-LINE SLIM RECESSED LED 4400	4442 / 4676	24,8	3000 / 4000	1160 x 70 x 75
X-LINE SLIM RECESSED LED 4400 TUNABLE WHITE	4304÷4574 (2700÷6500 K)	32	2700 ÷ 6500	1160 x 70 x 75
X-LINE SLIM RECESSED LED 5500	5552,5 / 5845	31	3000 / 4000	1441 x 70 x 75

Technical drawing:

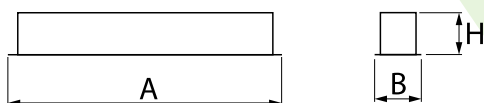

Light and electrical features:

Light source	LED
Voltage	220..240 V, 50..60 Hz
Lifetime of LED sources [h]	100000/50000
Lx/By	L80/B10
CRI	>80
SDCM (LED sources)	3
Photobiological risk class (IEC/EN 62471)	RG0
Operating temperature range [°C]	5 ÷ 35
Driver	standard on/off (E) DIM DALI (EDD) *
Power factor cos φ	>0,95

* Variant to specify when ordering

Mechanical features:

Assembly	mounted in plasterboard ceilings
Material	aluminum
Color	RAL 9005 (black) RAL 9006 (grey) anodised aluminum RAL 9016 (white) *
Diffuser	Micro-PRM (micro-prismatic diffuser PMMA)

Additional information:

The luminaire can be made in CLO version.

Note: The power shown refers to the whole system (tolerance +/- 10%).
The given luminous flux refers to LED light sources (tolerance +/- 10% depends on the value of the colour temperature).
Technical data may be changed. Photos of the luminaires may differ from reality.
Date of last update: 13-12-2024